

COMPRESSION HANDLE PART NUMBER	ROTATION DIRECTION (90° FROM FRONT)	TRAY FINISH (SEE NOTES)	MOUNTING HOLES OR CD STUDS?
GC2501LXBPCD-C	COUNTER CLOCKWISE (LH)	BLACK POWDERCOAT	10-24 STUDS
GC2501LXBPMH-C	COUNTER CLOCKWISE (LH)	BLACK POWDERCOAT	HOLES
GC2501LXCRC D-C	COUNTER CLOCKWISE (LH)	CHROME	10-24 STUDS
GC2501LXCRMH-C	COUNTER CLOCKWISE (LH)	CHROME	HOLES
GC2501RXBPCD-C	CLOCKWISE (RH)	BLACK POWDERCOAT	10-24 STUDS
GC2501RXBPMH-C	CLOCKWISE (RH)	BLACK POWDERCOAT	HOLES
GC2501RXCRC D-C	CLOCKWISE (RH)	CHROME	10-24 STUDS
GC2501RXCRMH-C	CLOCKWISE (RH)	CHROME	HOLES

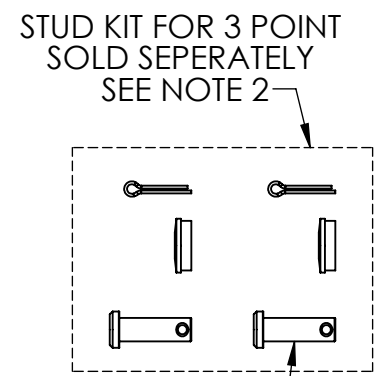
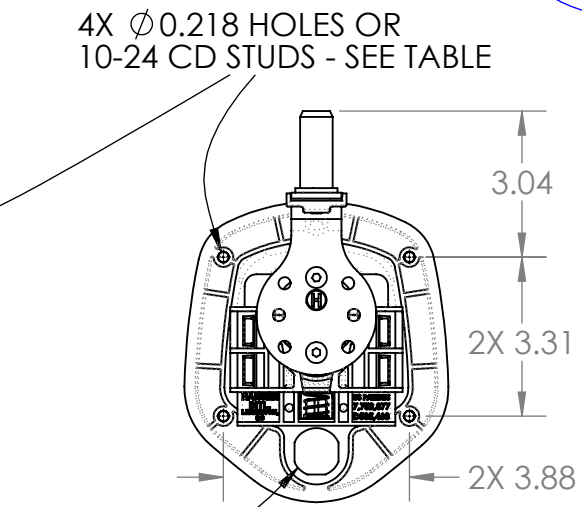
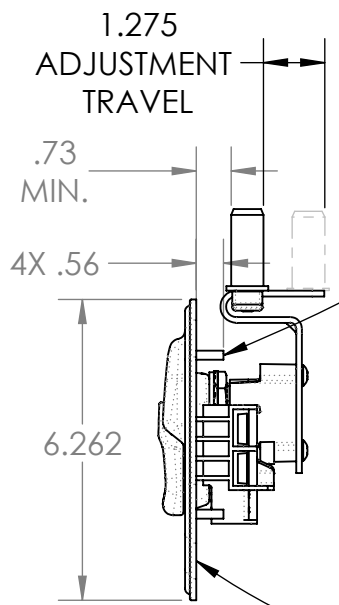
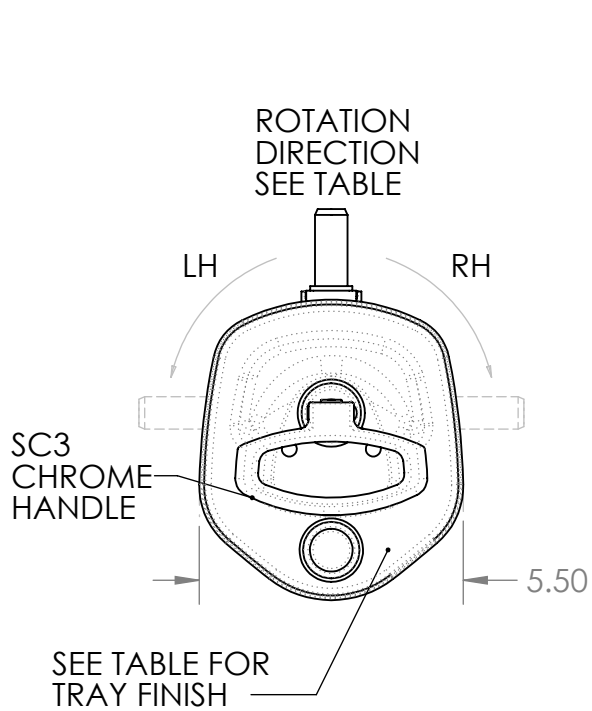
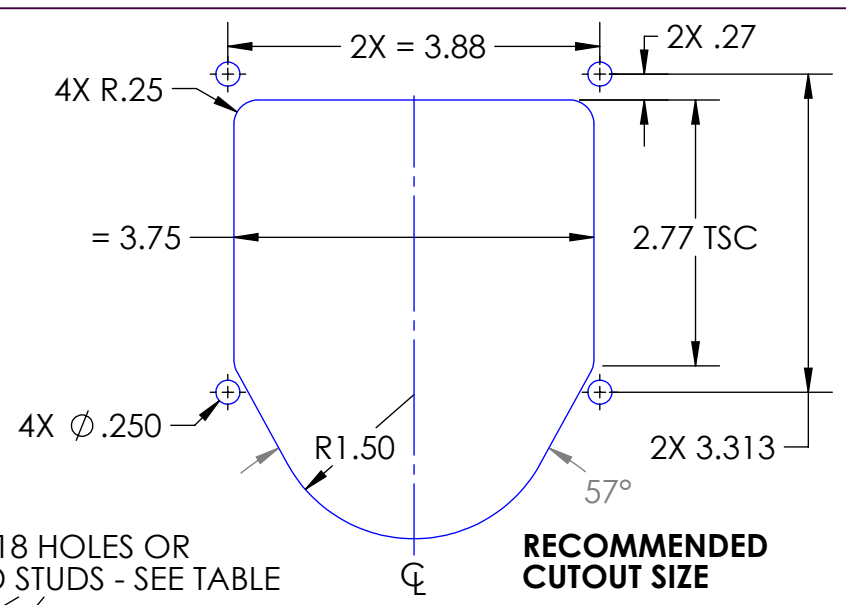

- NOTES:
1. CODEABLE KEY CYLINDER KITS SOLD SEPARATELY AND MUST BE INSTALLED AND CODED TO CHASSIS BY CUSTOMER REFER TO HANSEN DRAWING NUMBER INST00014 FOR INSTALLATION PROCEDURE.
  2. FOR 3 POINT OPTION, USE HANSEN STUD KIT P/N PMISC217.
  3. MATERIALS: FORMED SHEET METAL TRAY WITH STEEL, ZINC ALLOY (ZAMAK) AND POLYMER INTERNALS.
  4. FINISH: SEE TABLE.
  5. DIMENSIONS ARE REFERENCE ONLY.

DESCRIPTION: GUARDIAN COMPRESSION HANDLE, CODEABLE	Weight 2.3 LBS
Part Number:  GC2501XXXXXX-C	REV -
PROPRIETARY NOTICE: THIS DRAWING IS EXCLUSIVELY THE PROPERTY OF HANSEN INTERNATIONAL INC. AND SHALL NOT BE COPIED OR PASSED ON TO A THIRD PARTY WITHOUT OUR PRIOR WRITTEN APPROVAL. WE WILL RETAIN ALL RIGHTS FOR PATENT ISSUE OR REGISTRATION OF DESIGN.	
©2020 Hansen International, Inc.	